

# WHEEL COVERS

Front and Rear  
Wheel Covers  
manufactured  
from heavy-  
gauge premium  
stainless steel.



## Product Information - Wheel Covers

**Stud-Piloted** - Products designated for "stud-piloted" wheels typically have ten (10) lug holes. Five (5) of the holes are 1.25" in diameter and have a slight taper that conforms to the shape of the lug nut. The other five (5) lug holes are 1.75" in diameter and are sized to slip over the existing lug nuts without removal.

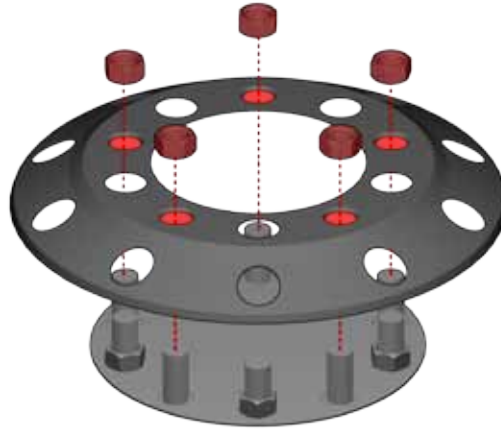

**Installation Tip** - Our products are designed to install easily, without removing the wheel or all fasteners. Simply remove five (5) of the lug nuts, slip the Wheel Cover over the wheel, and secure with the lug nuts you removed earlier.

To prevent damaging the product, avoid over-torquing the lug nuts. Do not exceed the wheel manufacturer's recommendations.

**Hub-Piloted** - Products designated for "hub-piloted" wheels typically have ten (10) lug holes. Five (5) of the holes are 1" in diameter to fit over the lug bolt only, and five (5) lug holes are 1.88" in diameter and are sized to slip over the existing lug nuts without removal.

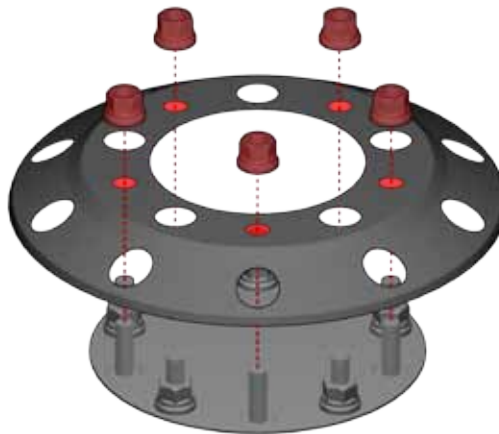

**Installation Tip** - Our products are designed to install easily, without removing the wheel or all fasteners. Simply remove five (5) of the lug nuts, slip the Wheel Cover over the wheel, and secure with the lug nuts you removed earlier.

To prevent damaging the product, avoid over-torquing the lug nuts. Do not exceed the wheel manufacturer's recommendations.